

The Farmer and the Cowman

Objective

Students will make booklets showing the difference between a ranch and a farm. The student will understand basic features of print. They will read common high-frequency words by sight.

Background

The difference between a farm and a ranch is the difference between how plants feed themselves and how grazing animals feed themselves. Plants stay in one place and get their food through their roots. Grazing animals, like beef cattle, sheep and horses, move around and eat grass. Farmers raise mostly plant crops. Ranchers raise mostly grazing animals. Since grazing animals must move around, ranches are usually larger than farms. Cattle cannot stay in one place but must be moved from pasture to pasture to give the grass a chance to grow back.

Many types of crops may be raised on a farm—pecans, wheat, vegetables, oats, etc. Some farmers raise more than one crop. Some farmers also keep animals, like chickens, pigs and dairy cattle, but animals kept on a farm do not eat much grass. Instead, the farmer brings most of their food to them.

Ranchers normally raise only one kind of animal, usually beef cattle or sheep.

These days it is difficult to tell the difference between a farmer and a rancher. A farmer who grows crops may also have a herd of cattle. A rancher who raises cattle may also grow alfalfa or some other crop to feed his animals.

In Oklahoma some parts of the state are better for growing crops and some are better for grazing cattle. The flatlands of central Oklahoma and southwestern Oklahoma are good for growing crops. Southeastern Oklahoma is more rugged. It is difficult to grow crops there because the land is rocky and mostly covered with timberlands. But there is plenty of grass for cattle and sheep to eat, so there are more ranches there.

Procedures

1. Read and discuss background and vocabulary. Discuss the difference between rural and urban areas.
—Students will use a combination of drawing and writing to show the difference between either a farm and a ranch or a rural and urban area.
2. Hand out worksheets.
—Students will color the pictures in the two booklets.

Oklahoma Academic Standards

KINDERGARTEN

Speaking and Listening:
R.1,2,3,4; W.1,2. Print Concepts:
3,5. Reading and Writing
Process: R.1,3. Critical Reading
and Writing: R.3; W

GRADE 1

Speaking and Listening:
R.1,2,3,4; W.1,2. Reading and
Writing Process: R.1,3
Geography:
1
Music History and Culture: 2.
Performing: 1
Creating: 2

GRADE 2

Speaking and Listening:
R.1,2,3,4; W.1,2. Reading and
Writing Process: R.1,3
Visual Art—3.2
Music History and Culture: 2.
Performing: 1
Creating: 2

Materials

scissors
crayons
stapler

Vocabulary

crop—a plant or animal or plant or animal product that can be grown and harvested

farm—a piece of land used for growing crops or raising livestock

graze— to feed on growing grass or herbs

ranch—a place for the raising of livestock (as cattle, horses, or sheep) on range

range—open land over which livestock may roam and feed

- Students will cut out and fold the pages of the booklets, following the directions on the pages.
 - Students will staple the booklets together.
 - Read the booklets together as a class, then have students take the booklets home to read to their parents.
3. Students will follow the instructions included with this lesson to make Barn Books. After the books are completed, students may use them for one or more of the following activities.
- Alphabet: Create a page for each letter of the alphabet. Students will find items related to the farm that begin with each letter and decorate by drawing, coloring, writing or cutting and pasting pictures of each object.
 - Talk about each of the seasons and what might be happening on the farm during that time of year. What things are harvested in the summer? (See the link to the “Crop Calendar” on the website: <http://www.clover.okstate.edu/fourh/aitc/calendar/cropcal.html>) In the fall? When does planting occur? What is the weather like during each season? Students will dedicate a page for each season and color pictures, write and cut pictures from magazines to illustrate.
 - Students plant a bean in a cup and keep a journal of its growth.
4. Before statehood, when Oklahoma was still a territory, some conflicts arose between farmers and ranchers. The song “The Farmer and the Cowman Should be Friends,” from the musical *Oklahoma*, provides a simple explanation for the conflict. Some of the words to the song are included in this lesson. Teach the song to your students, and divide them into “Farmer” and “Rancher” groups to perform it.

Extra Reading

Cipriano, Jerry, *Harvest Time*, Red Bricklearning, 2003.

Gibbons, Gail, *Pigs*, Holiday House, 2003.

Green, Emily, *Farm Animals: Sheep*, Bellweather, 2007.

Murphy, Andy, *Out and About at the Dairy Farm*, Picture Window, 2004.

Peterson, Cris, *Clarabelle: Making Milk and So Much More*, Boyds Mills, 2007.

Peterson, Cris, *Harvest Year*, Boyd’s Mills Press, 2009.

Ray, Hannah, *Chickens (Down on the Farm)*, Crabtree, 2008.

Ray, Hannah, *Cows (Down on the Farm)*, Crabtree, 2008.

Ray, Hannah, *Pigs (Down on the Farm)*, Crabtree, 2008.

Ray, Hannah, *Sheep (Down on the Farm)*, Crabtree, 2008.

The Farmer and the Cowman

Cut on the dotted lines. Fold on the solid lines.

There are women ranchers in Oklahoma.



2

staple here

The rancher takes care of the cattle.

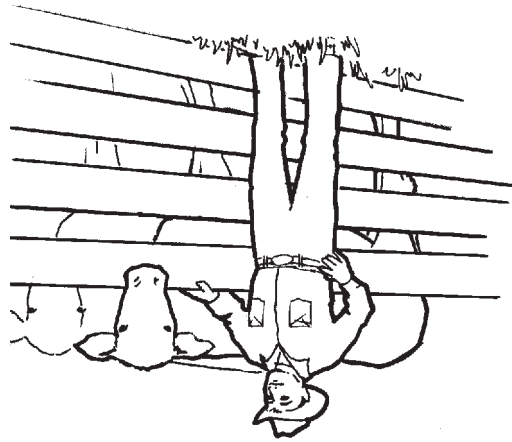

2

3

4

My Ranch

by _____



Wheat is growing to feed the animals in winter.

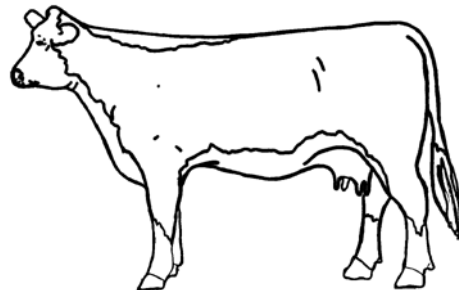

The Farmer and the Cowman

Cut on the dotted lines. Fold on the solid lines.

Ranchers work to keep their animals healthy.

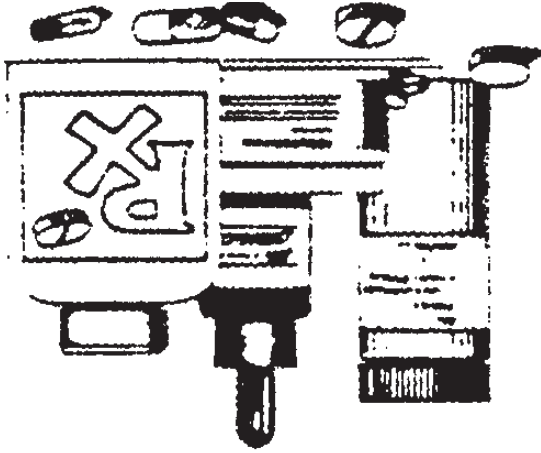

L

Some ranchers own horses to help with the work.

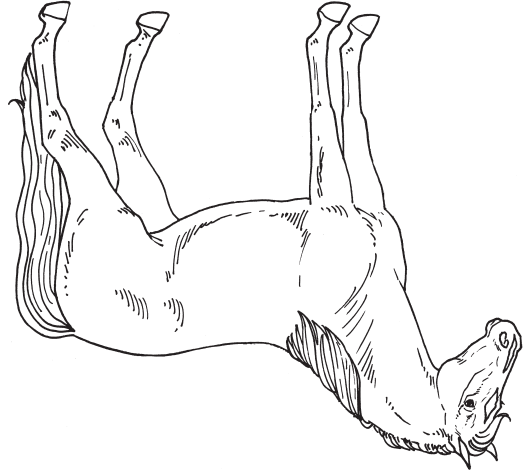

9

8



Many of the things we use are made from beef cattle.

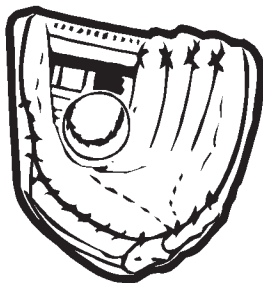

5

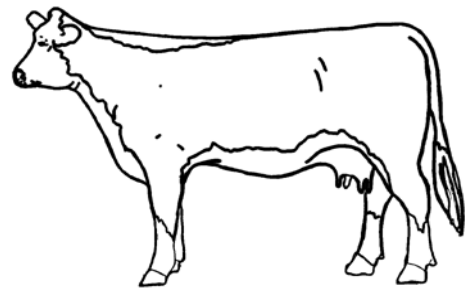

Cattle eat wheat and other grasses.

The Farmer and the Cowman

Cut on the dotted lines. Fold on the solid lines.

Farmers use tractors to do many different jobs.

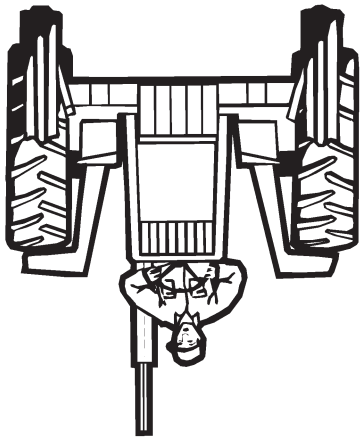

3

The farmers care for the fields

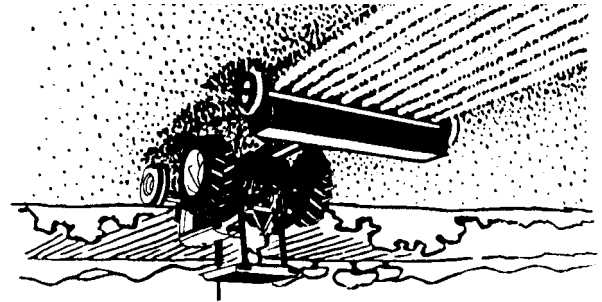

staple here

2

My Farm

by _____

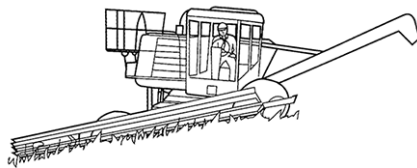

The farmer harvests the crops.

4

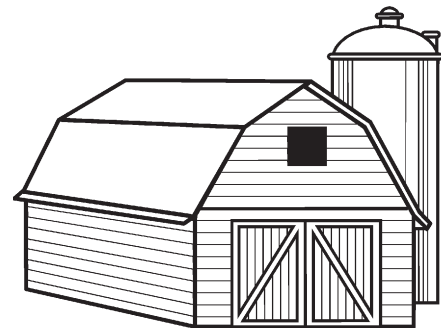

The Farmer and the Cowman

Cut on the dotted lines. Fold on the solid lines.

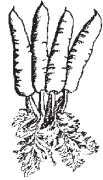

In our garden we grow many vegetables.



staple here

We own a cow that gives us fresh milk.



9

8



Our farm is a very busy place.

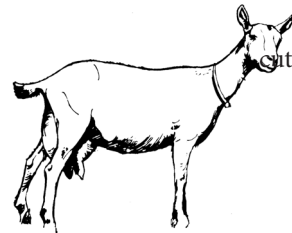

We have lots of animals here.

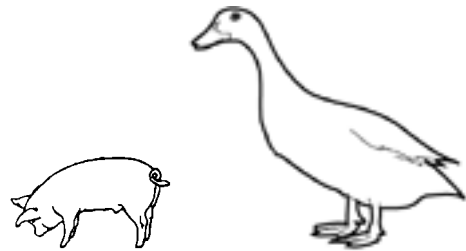

Barn Book

1. Print the cover sheet (see next page) on red paper. Make sure your printer is set to print the actual size or the lines will not line up correctly. Place the red cover sheet on top of a plain white sheet of paper (8 1/2 X 11) and fold them together horizontally (hamburger fold).
2. Cut out the roof shape out for the barn, cutting through all thicknesses.
3. Separate the cover sheet from the white sheet.
4. On both sheets, measure and mark the folds 1 inch from the outer edges. Hint: For younger students, mark an index card at the 1-inch distance on both sides. The student can then lay the index card on top of the folds to mark the proper distance.
5. On the red cover page cut up on the crease from the top and bottom edge to the marked spot.
6. On the white folded sheet, start at one of the marked spots and cut out the fold between the two marks. Do not cut into the fold too deeply. Just shave it enough to make an opening.
7. Unfold the red cover sheet and roll it bottom to top like a burrito. Place the burrito through the cutout in the white sheet, making sure your are matching the rooftops, and then open the burrito and slide the slots on the barn page to fit into the crease on the white page. Fold the pages together to form your barn book.

Barn Book activity adapted from Illinois Ag in the Classroom

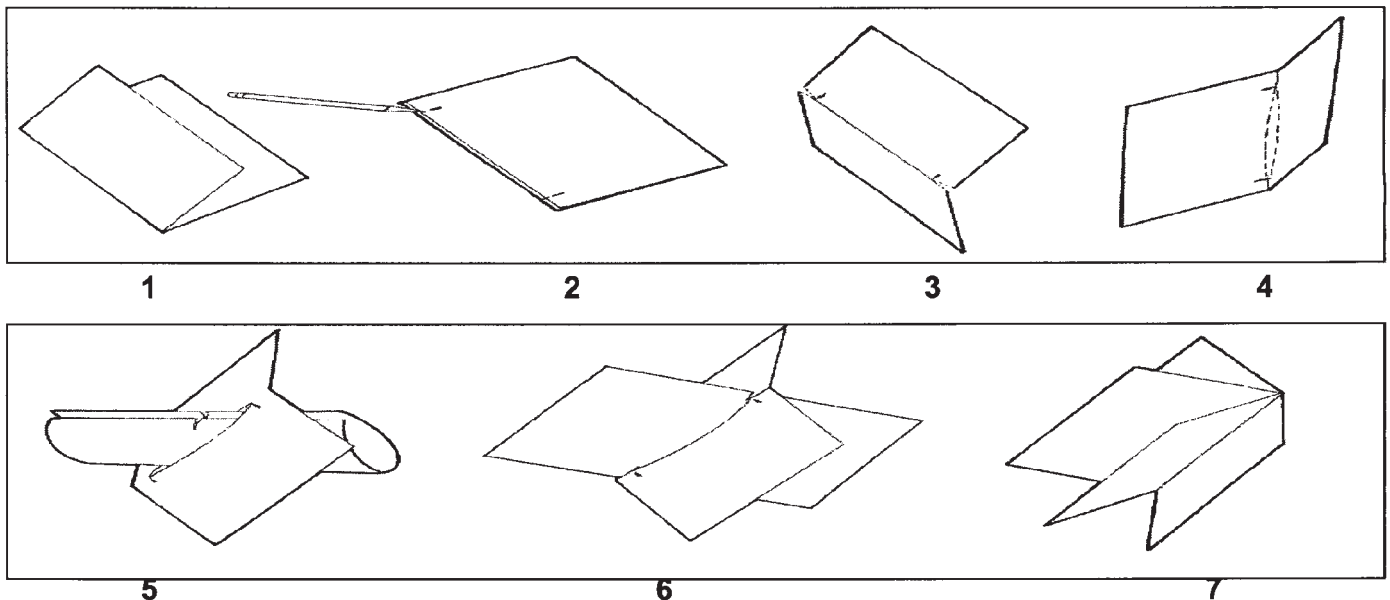

WARR

S,

PUNOON
AII

The Farmer and the Cowman

Chorus:

The farmer and the cowman should be friends,
Oh, the farmer and the cowman should be friends.
One man likes to push a plough, the other likes to chase a cow,
But that's no reason why they can't be friends.

Territory folks should stick together,
Territory folks should all be pals.
Cowboys dance with farmer's daughters,
Farmers dance with the ranchers' gals.

Farmer:
I'd like to say a word for the farmer,
He come out west and made a lot of changes

Farmer:
He came out west and built a lot of fences,

Rancher:
And built them right across our cattle ranges!

Back to Chorus

Rancher:
I'd like to say a word for the cowboy,
The road he treads is difficult and stony.
He rides for days on end with jist a pony for a friend,

Farmer:
I sure am feelin' sorry for the pony!

Back to Chorus

From *Oklahoma*, by Richard Rodgers and Oscar Hammerstein