

# The ABCs of Oklahoma Agriculture



Coloring and Activity Book



Ag in the Classroom lessons use agriculture-related activities and research-based background material to teach National Standards in language arts, math, science, reading, social studies and visual arts.  
See P.A.S.S. chart on inside back cover.

For more information, contact us:

**Oklahoma Ag in the Classroom**

Oklahoma Department of Agriculture, Food and Forestry

Jamey Allen • (405) 522-6768

Mary Ann Kelsey • (405) 522-5513

Dana Bessinger • (405) 522-2105

P.O. Box 528804 • Oklahoma City, OK 73152

Oklahoma Cooperative Extension Service

Pat Thompson or Judy Ferrell

(405) 744-8889

205 4-H Youth Development Building • Stillwater, OK 74078

**[www.agclassroom.org/ok](http://www.agclassroom.org/ok)**

A

**A is for ag.**

Ag is short for agriculture. Agriculture is cultivating soil, producing crops and raising livestock.





B

**Beef, it's what's for dinner®.**  
Beef has **ZIP** — **Z**inc, **I**ron, **P**rotein.



C

**Cotton is “the fabric of our lives.”** Your blue jeans and t-shirts are made from cotton fibers. Cotton fibers grow on the seed of the cotton plant.

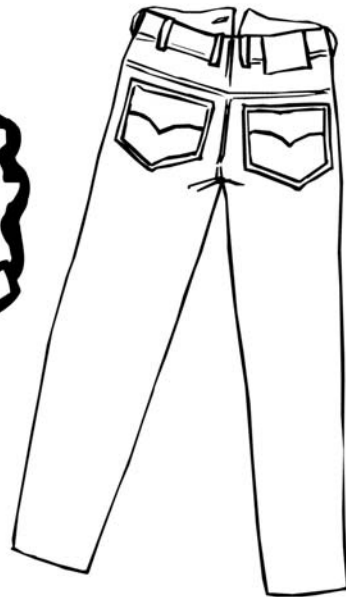
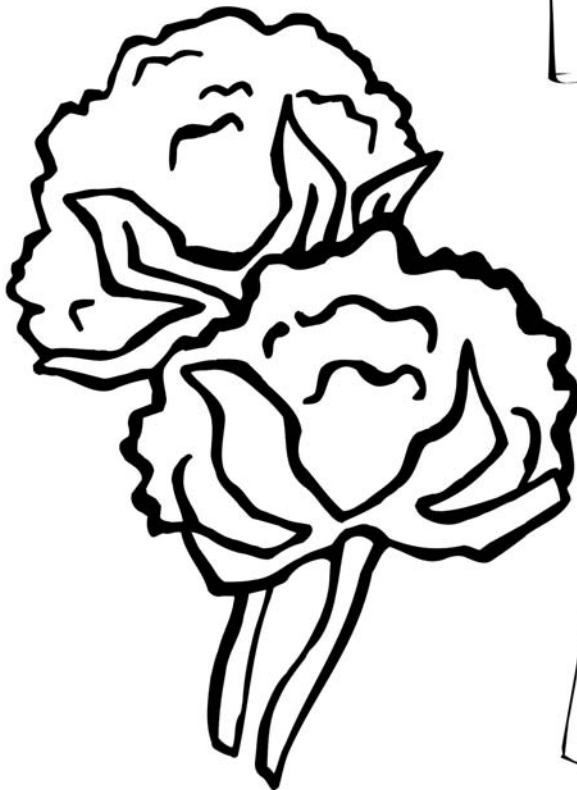
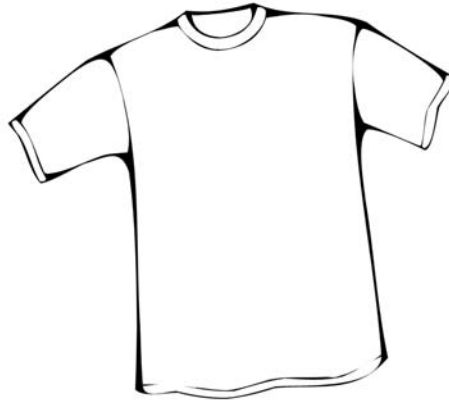

D

**D is for dog.**

Some dogs help sheep ranchers herd and protect their sheep.

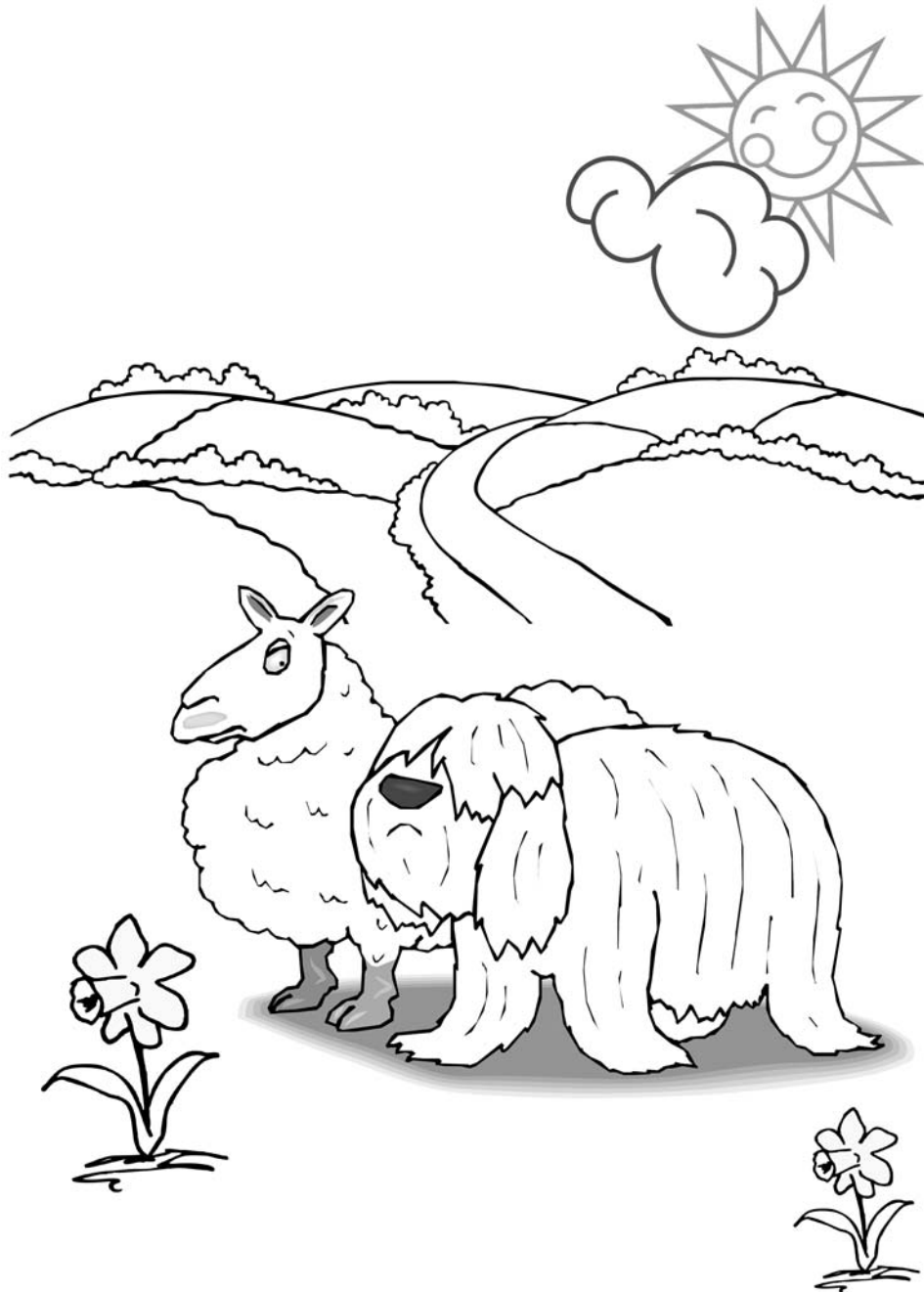

E

**E is for eggs.**

Eggs are good for breakfast.

Hatching chicks from eggs is fun.

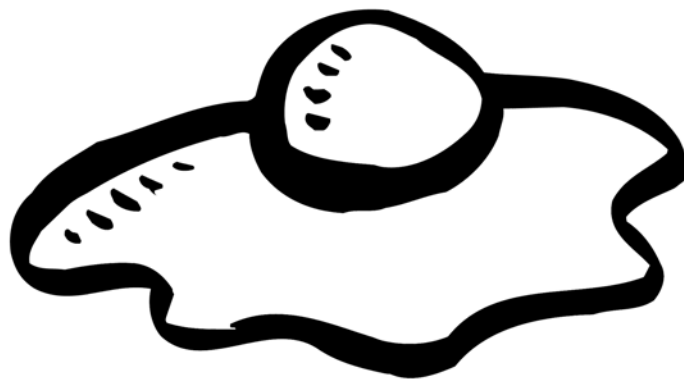
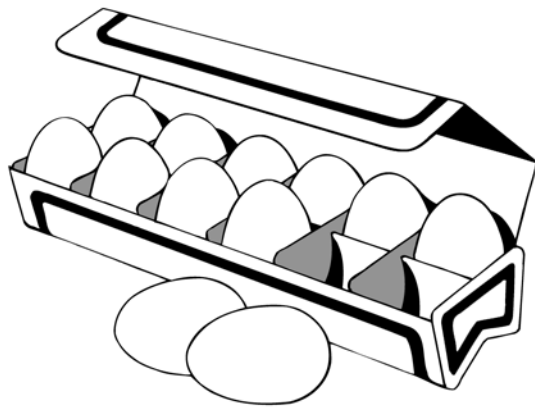
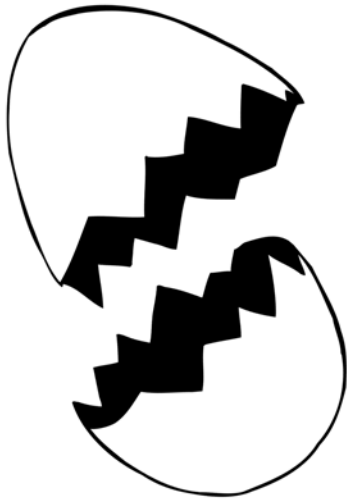

F

**F is for feed.**

In Oklahoma, we grow corn, oats, hay and grain sorghum to feed farm animals.

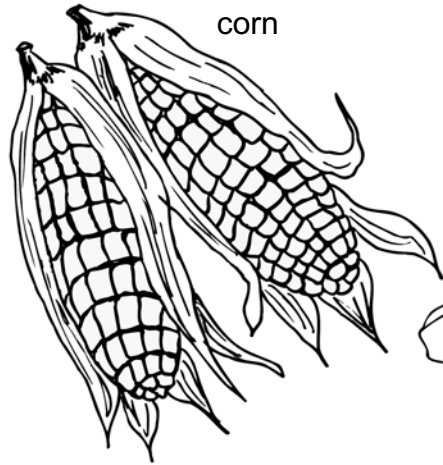

corn



grain sorghum



hay



G

**G is for greenhouse.**

A greenhouse is a sheltered place to start new plants until they are ready to go outside.

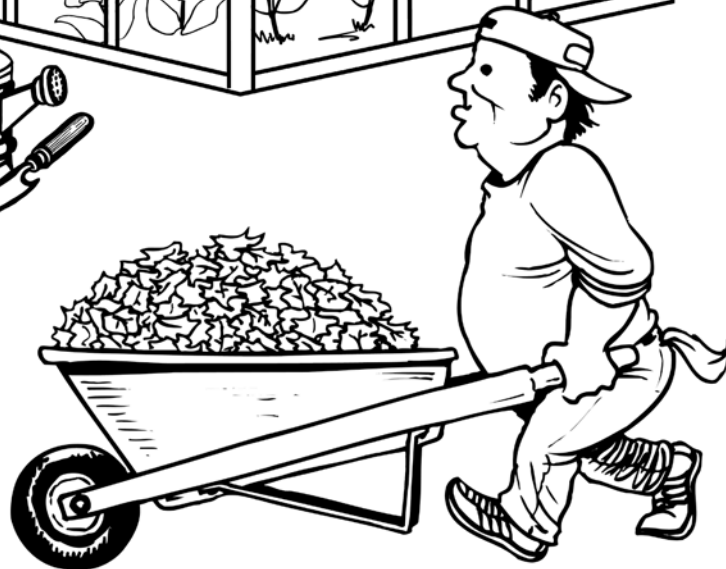
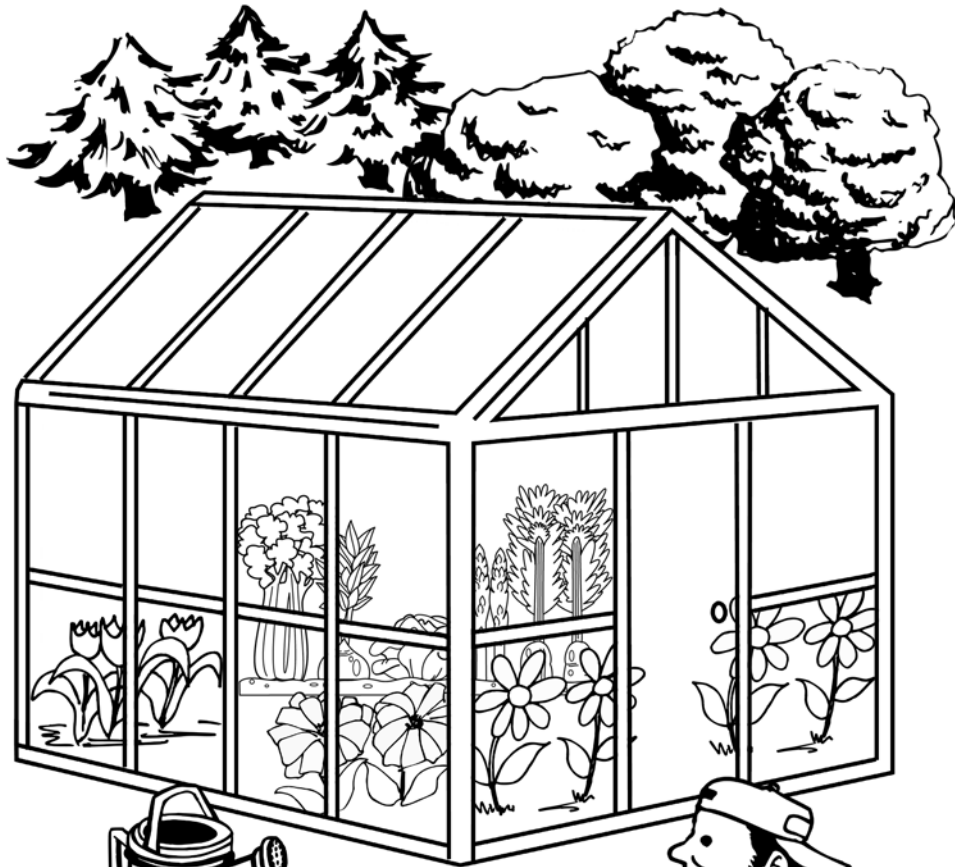

H

**H is for horses.**

Horses are fun. In Oklahoma, we have race horses. Some horses help ranchers herd their cattle.

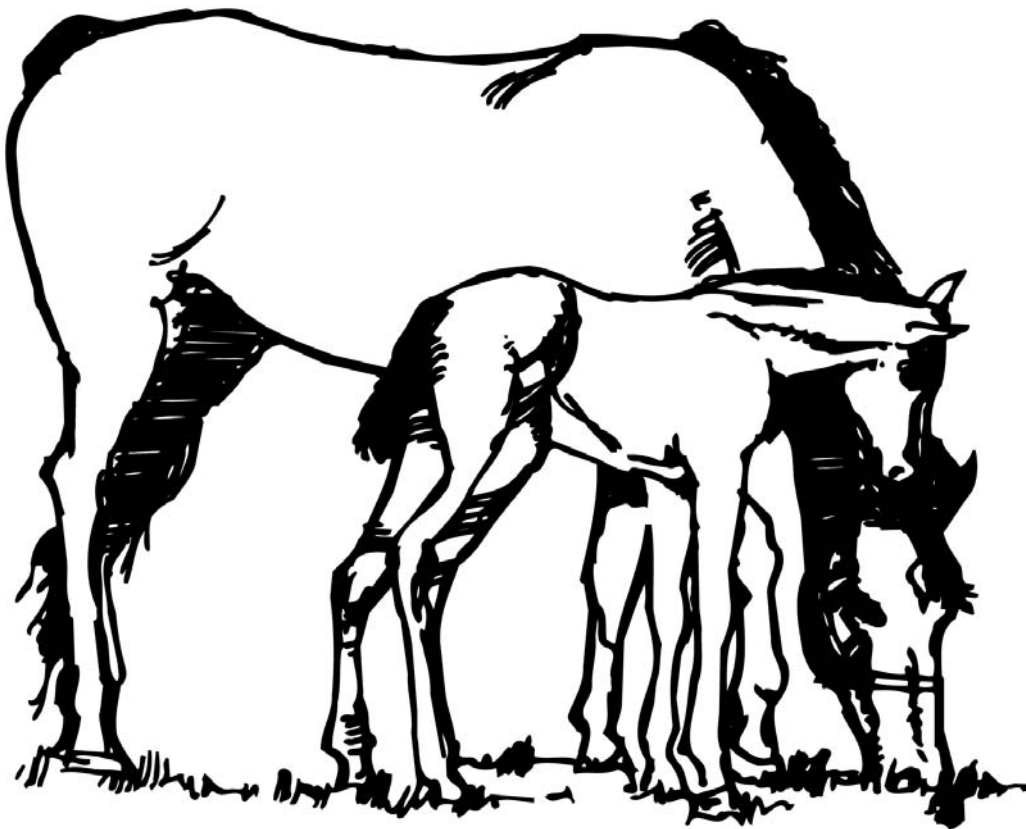

**I is for insects.**

Insects can be a farmer's friend or enemy. The aphid is an enemy because it eats the farmer's plants. But the ladybug is a friend because it eats the aphids.

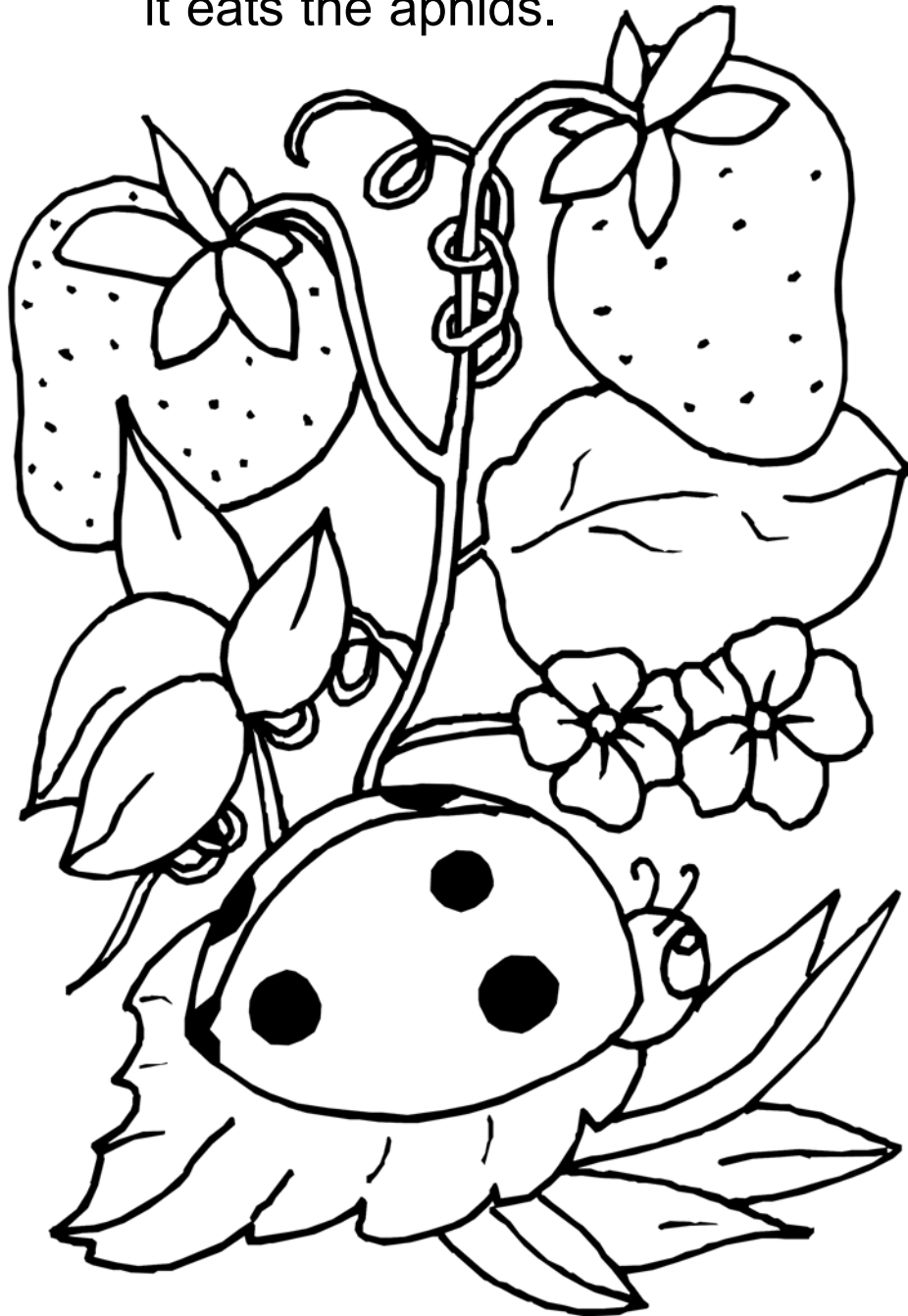

J

**J is for jelly.**

In Oklahoma we grow peaches, grapes, apples, strawberries and plums to make jelly.

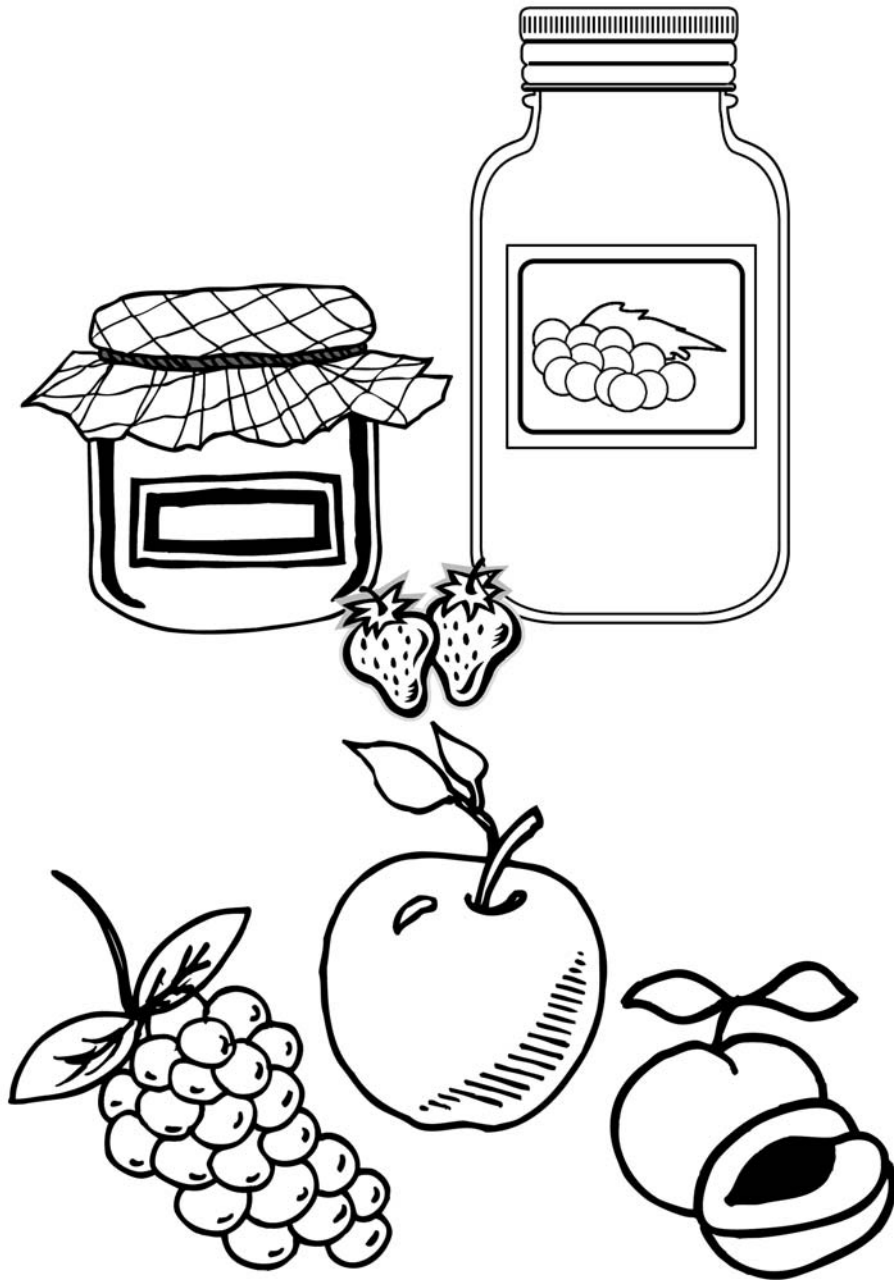

**K**

**K is for kabob.**

Have you ever eaten a kabob grilled in the backyard with vegetables and meat? Yum - Yum!!





L

## L is for legume.

Legumes are good for the soil and good for you. Soybeans, peanuts and green beans are legumes. You eat the seed of a legume.

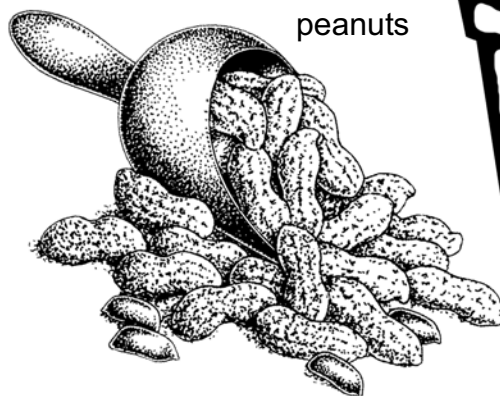
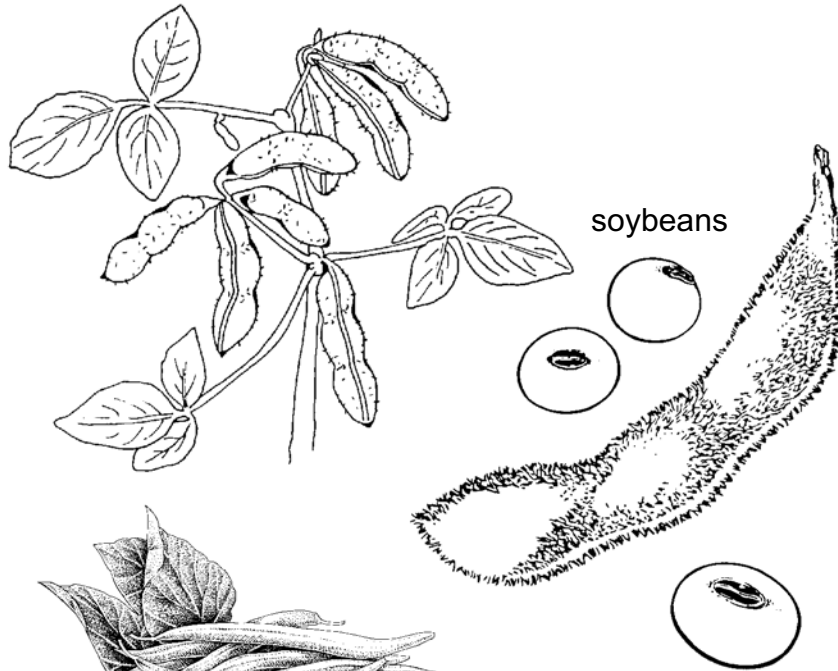

M

**M is for milk.**

It makes a body grow. We get whipping cream, butter and cheese from milk.

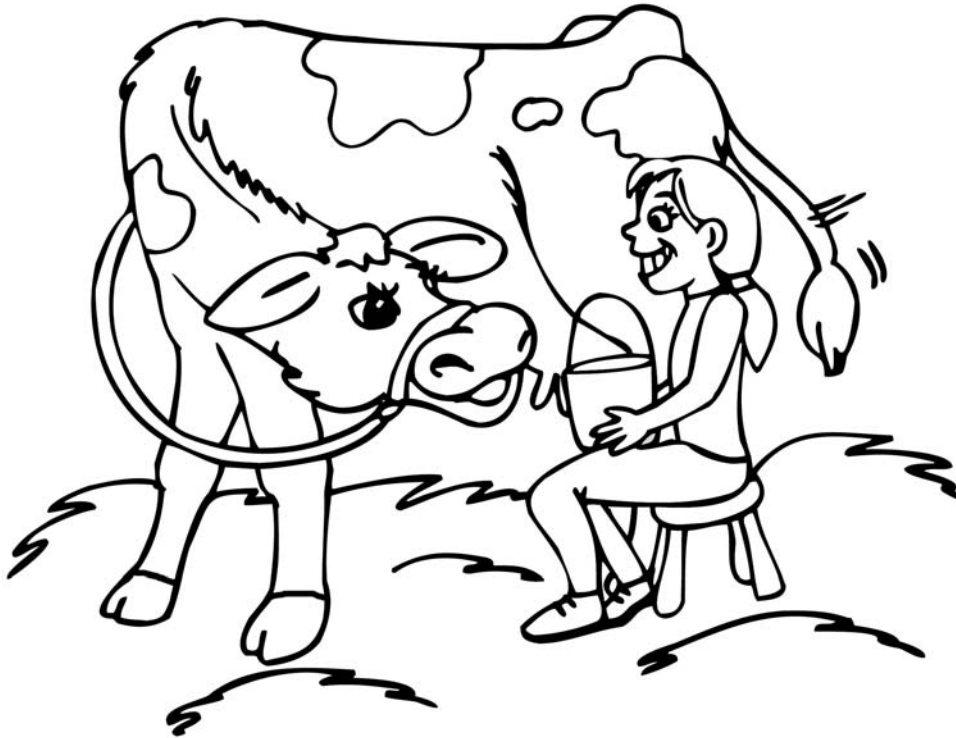

N

**N is for nuts.**

The most common nut grown in Oklahoma is the pecan. Native pecans are very little, but quite tasty. Papershell pecans are larger, taste good and are easier to shell.

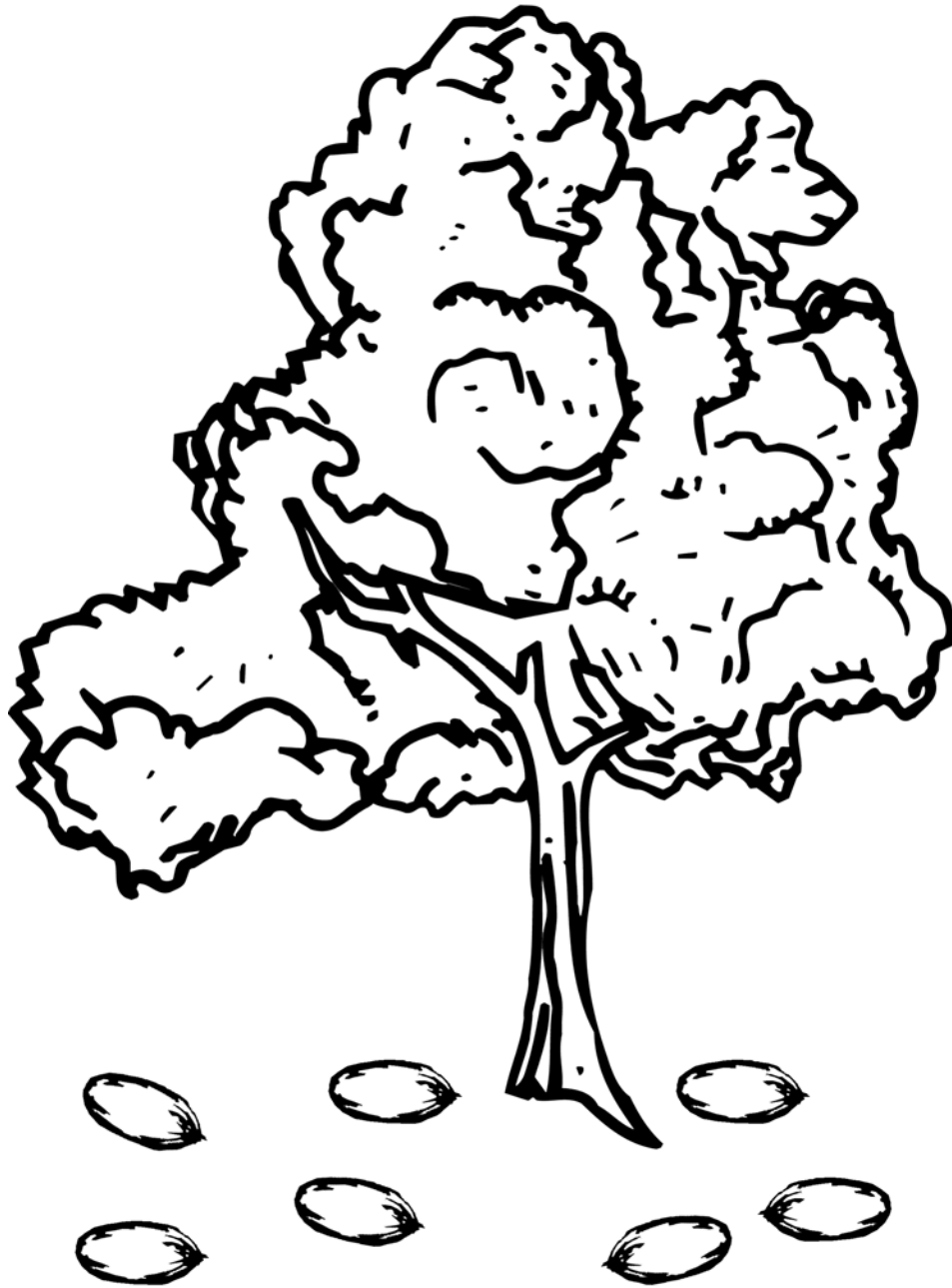

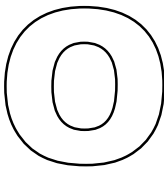

# O is for Oklahoma, The Sooner State.

Oklahoma provides wheat and beef to help feed the world.

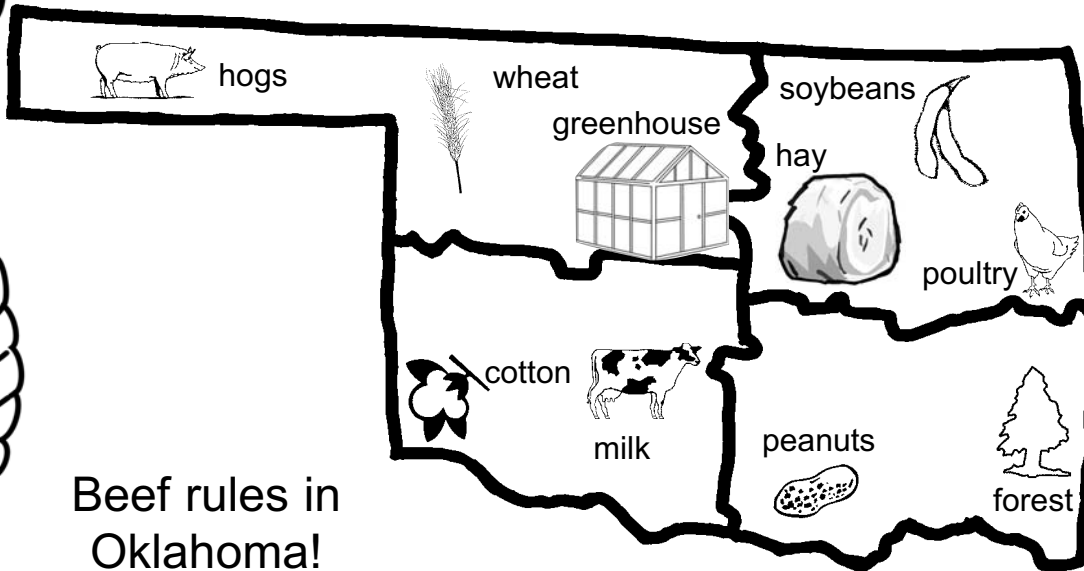

Beef rules in Oklahoma!



### Oklahoma's Top Ag Products

1. Cattle and Calves
2. Poultry & Eggs
3. Hogs & Pigs
4. Winter Wheat
5. Forest Products
6. Dairy Products
7. Greenhouse/Nursery
8. All Hay
9. Cotton Lint & Seed
10. Corn

*as reported in 2006*

P

**Pork is "The other white meat®."**

Hernando DeSoto brought the first pigs to North America in 1539.

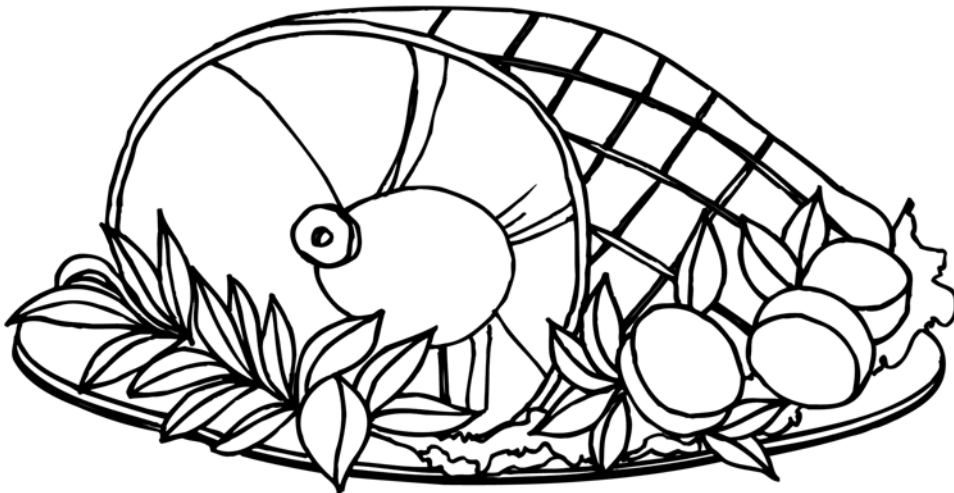



Q

**Q is for queen bee.**

There is only one queen bee in each  
bee hive.

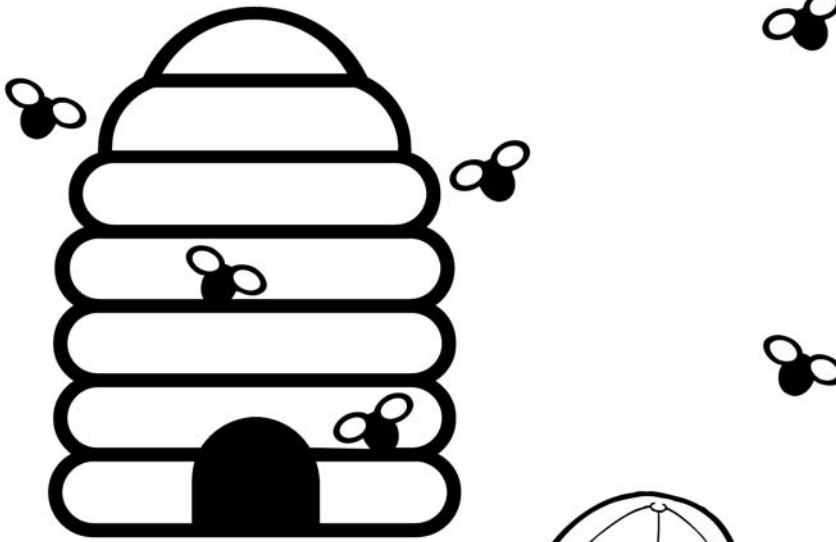

R

**R is for rain.**

Rain waters the crops that grow in Oklahoma.



S

**S is for sheep.**

Some sheep have wool. Some sheep have hair. Some sheep have both wool and hair.

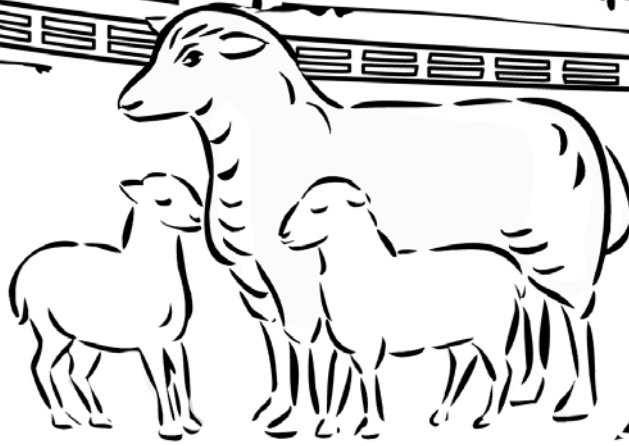

T

**T is for tractor.**

Farmers drive tractors to pull equipment to farm the land.



U

**U is for university.**

Oklahoma State University and Langston University are land grant colleges. They help farmers and ranchers do their jobs better!

Langston Lion  
Langston University



Pistol Pete  
Oklahoma State University



V

**V is for veterinarian.**

A veterinarian is an animal doctor.



W

**W is for wheat.**

Hard red winter wheat makes delicious bread.

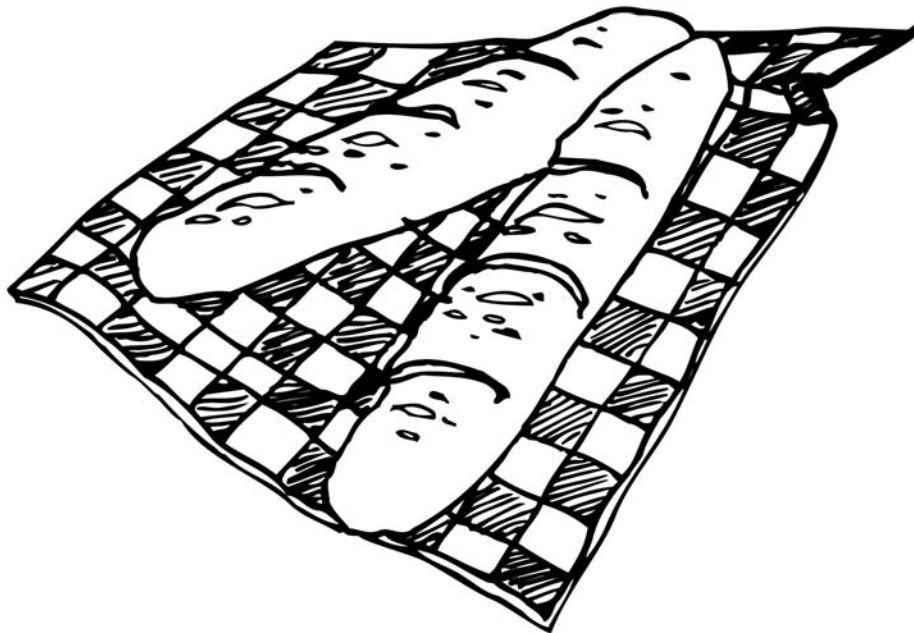
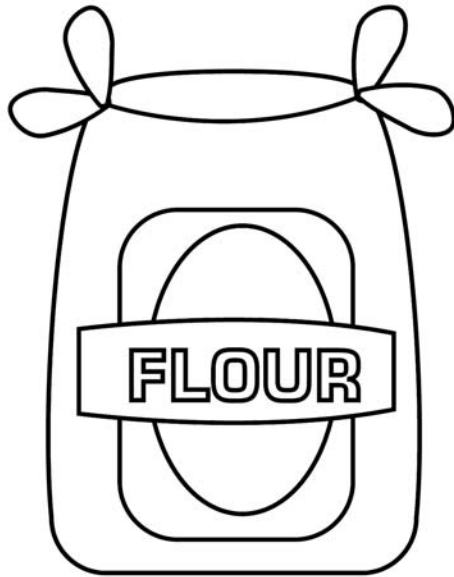

X

**X is for xylotomy.**

Xylotomy means cutting wood and getting it ready to study. You can count the rings to find out how old the tree is.

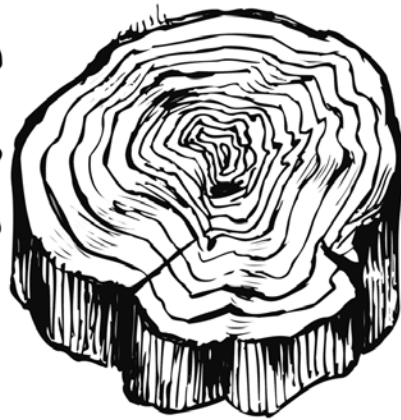

Y

**Y is for yam.**

In the United States, a yam is called a sweet potato. Sweet potatoes grow well in sandy soil. Does your family eat sweet potatoes at your Thanksgiving dinner?



Y

A

M

S

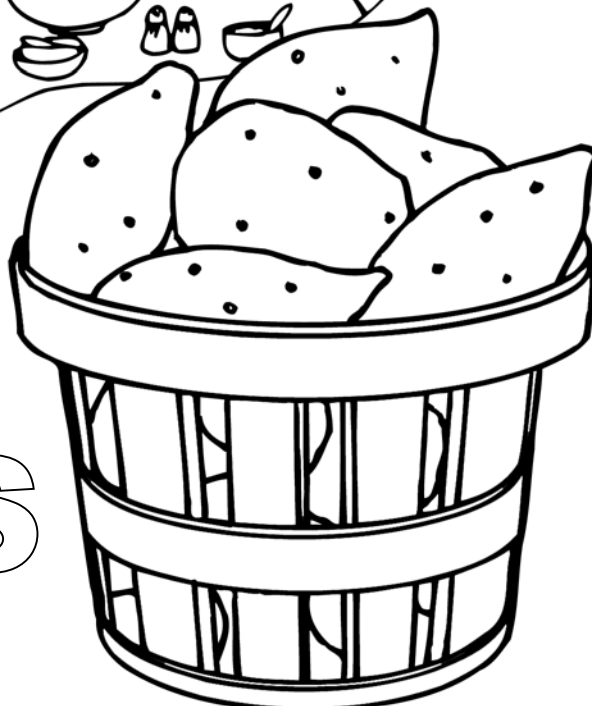

Z

**Z is for zucchini.**

A zucchini is a vegetable and is a kind of squash. It is green and tastes very good raw or cooked. Zucchini grows very well in Oklahoma gardens.

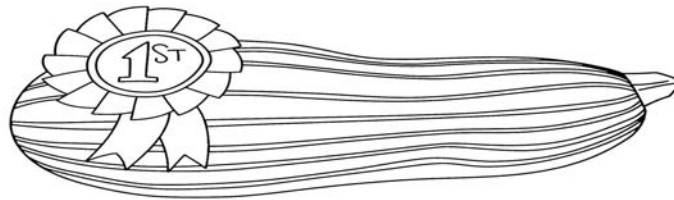

# Ag Word Search

G R A I N S O R G H U M J P W  
L E O X S S N A C E P Z M V A  
D H Y Y T U W W A B W M R D T  
Y O M R P B X O I L K O G N E  
D K N K S S Q I L G J Q X O R  
S O D P R O D U C T I O N T M  
S T A O T W G P V D S P W T E  
S O Y B E A N S E E H A Y O L  
Y K G N J F Z J H A B S W C O  
R J Z R T Z W C C X N P Y V N  
B K F L B S A H E W F U M P S  
U A Q T M E M Q E V O U T P N  
X V I X P G L Z T A N M M S R  
V M U Y N I W H J J T G B J N  
Q S K Y B G I U V G L C O R N

Look for these words above:

CORN  
COTTON  
GRAIN SORGHUM  
HAY  
OATS  
PEACHES  
PEANUTS  
PECANS  
RYE  
SOD PRODUCTION  
SOYBEANS  
WATERMELONS  
WHEAT



# Horses

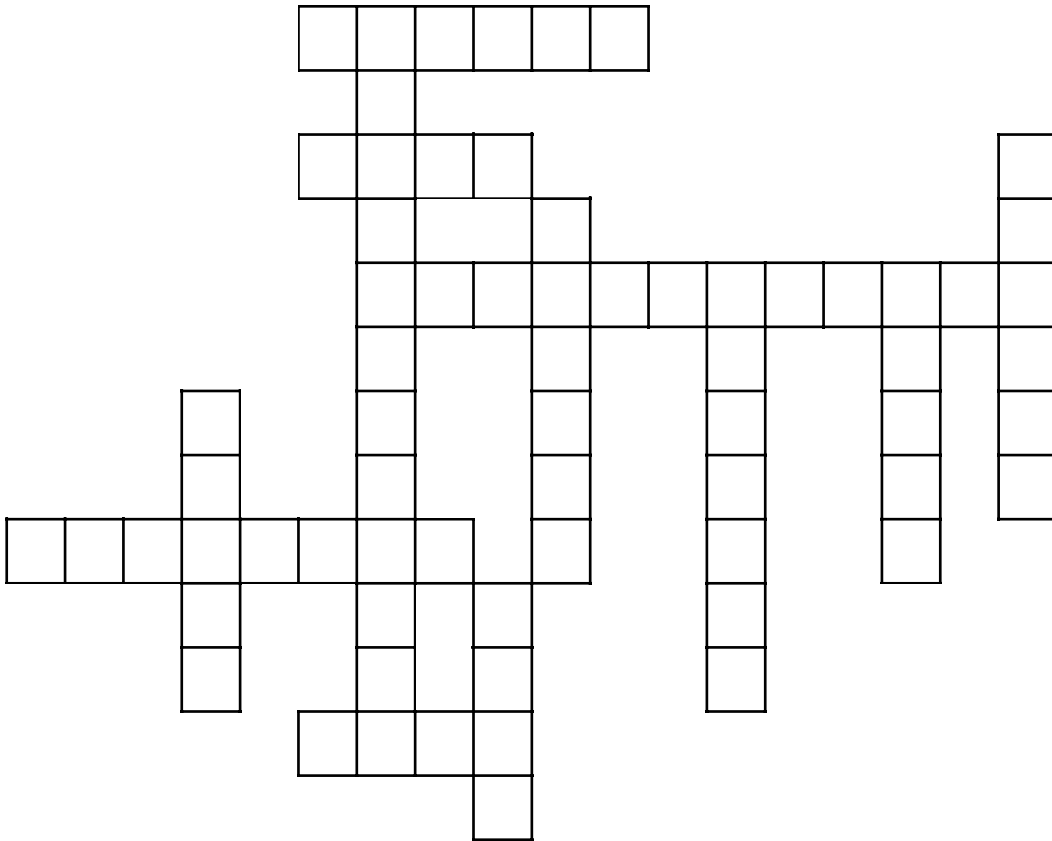

Fill in the crossword with these words:

- bridle
- equine
- filly
- gelding
- mane
- mare
- Quarter Horse
- rein
- rodeo
- saddle
- stallion
- Thoroughbred

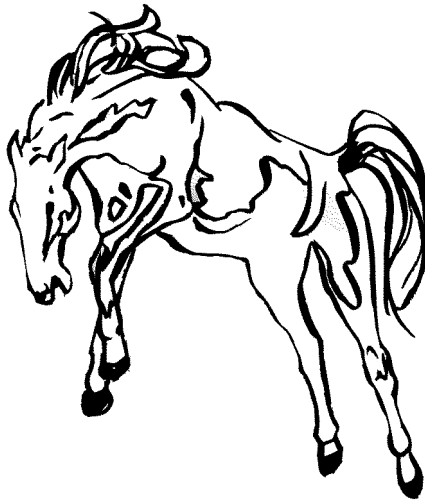

**There is one horse for every 10 people in Oklahoma.**



# Chickens

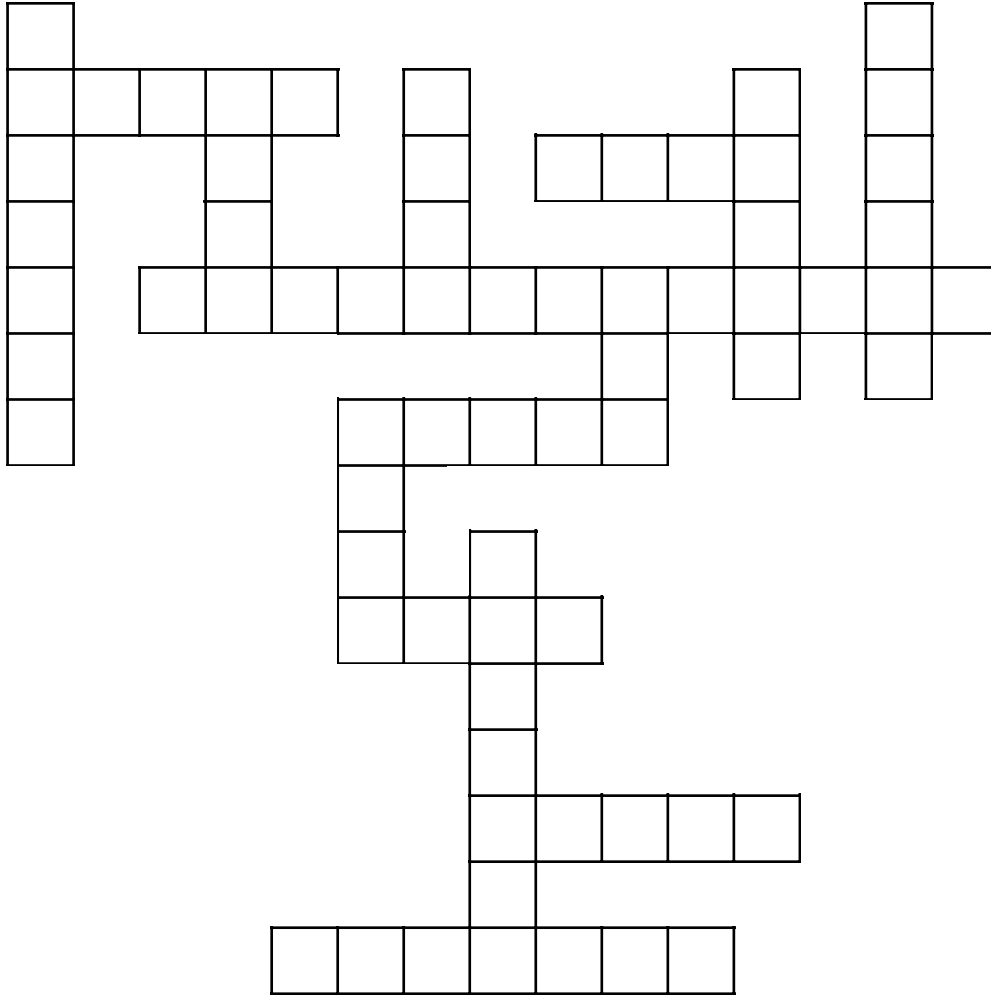

Fill in the crossword with these words:

beak  
capon  
chick  
comb  
coop  
down  
flock  
fowl

hen  
layer  
pullet  
rooster  
scratch  
spring chicken  
wattles

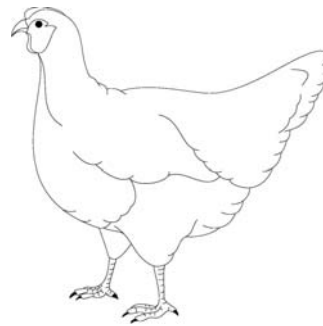

**The chicken is the closest living relative of the T-Rex.**

# Beef/Dairy

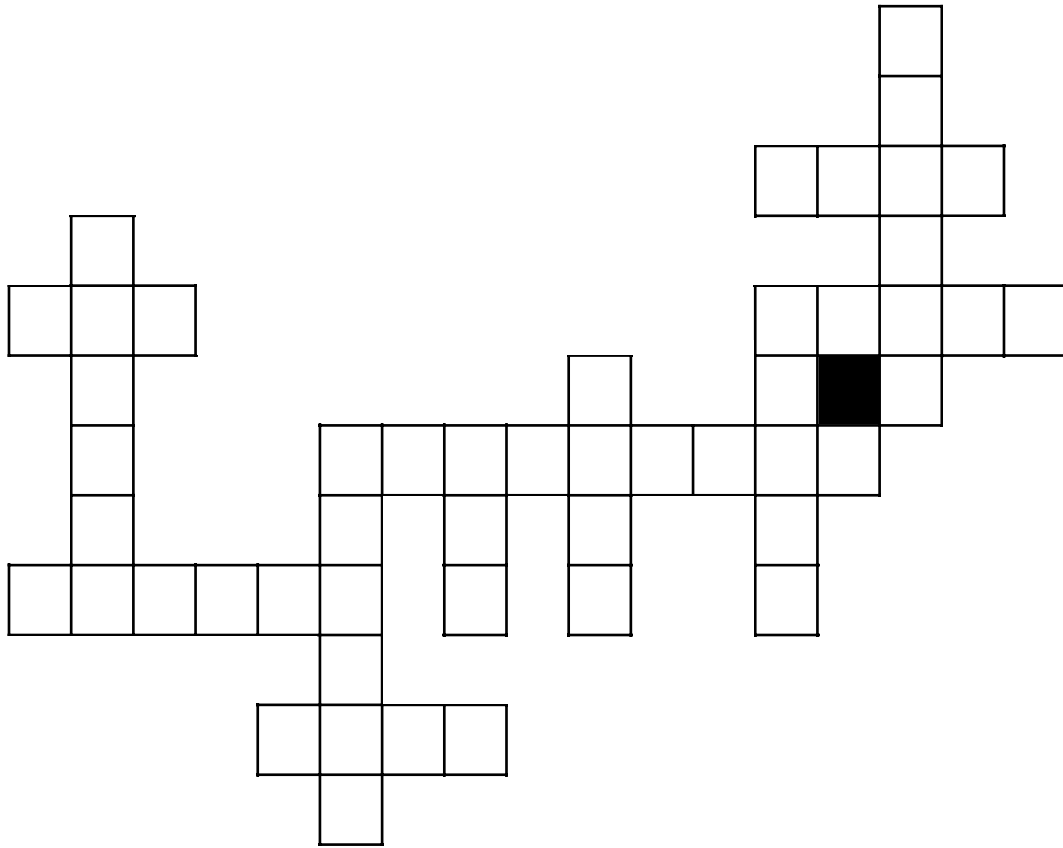

Fill in the crossword with these words:

beef  
bovine  
bull  
cow  
hamburger  
heifer  
horned

milk  
moo  
polled  
steak  
steer



**Each day, a cow spends six hours eating and eight hours chewing her cud.**

# Swine

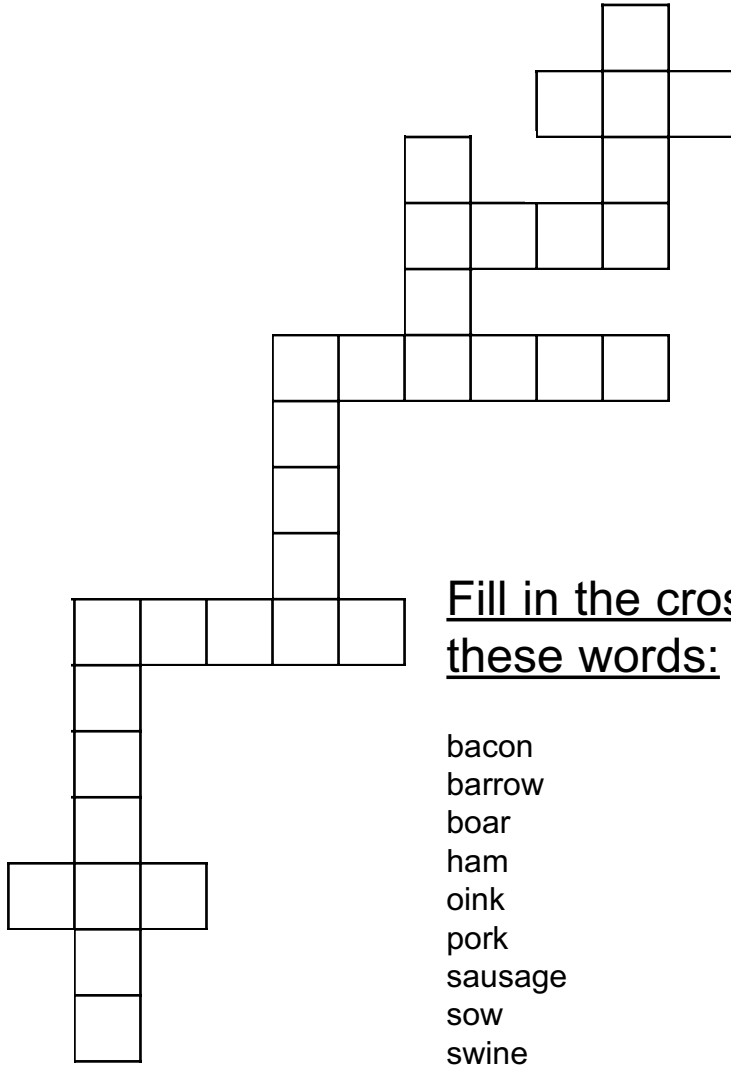

Fill in the crossword with these words:

- bacon
- barrow
- boar
- ham
- oink
- pork
- sausage
- sow
- swine

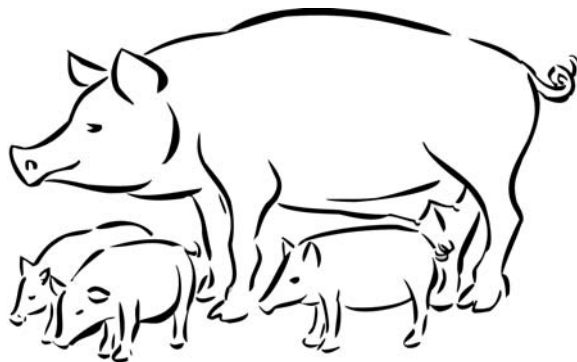

**Pigs can't sweat.**

# Sheep

Fill in the crossword with  
these words:

bah  
lamb  
lanolin  
mutton  
ram  
sheep  
wether  
wool

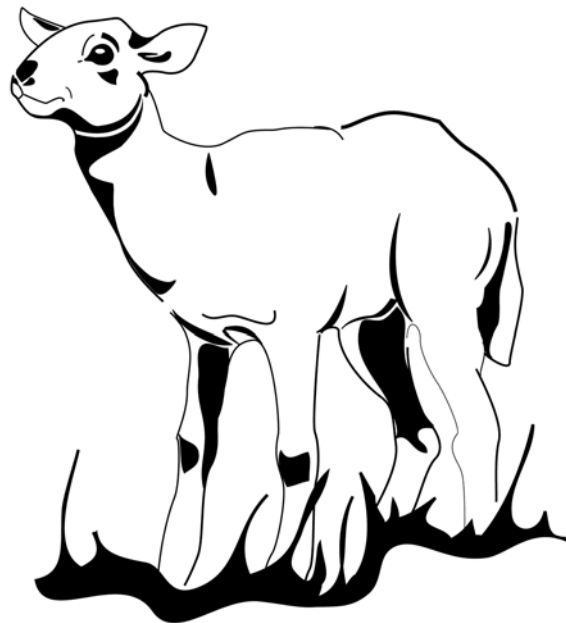
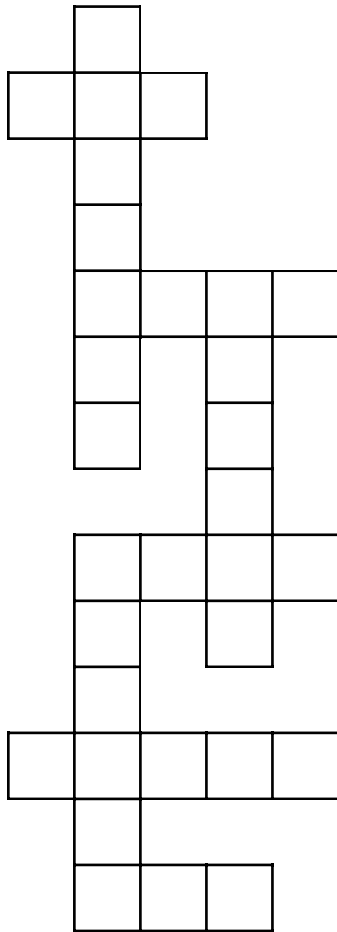

**Sheep are born with tails.**

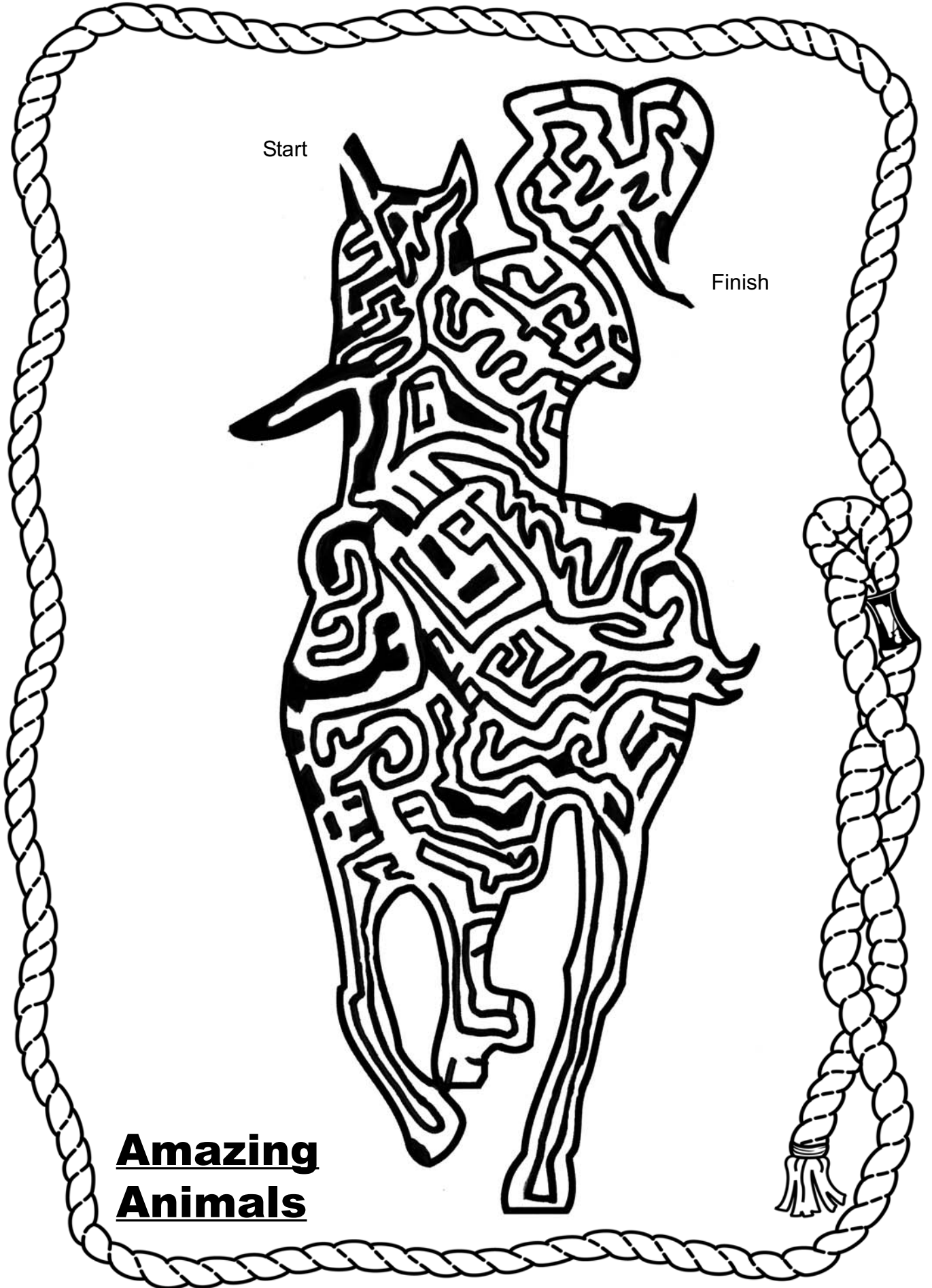

Start

Finish

**Amazing**  
**Animals**

# Ag Word Play

Write these words in ABC order on the barns:  
hay pasture fence wheat barn silo

**1.**

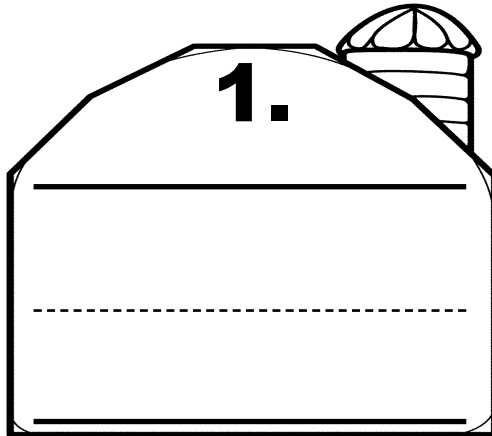

A barn with a silo on the right side. The barn has a large arched opening with a solid top line, a dashed middle line, and a solid bottom line for writing.

**2.**

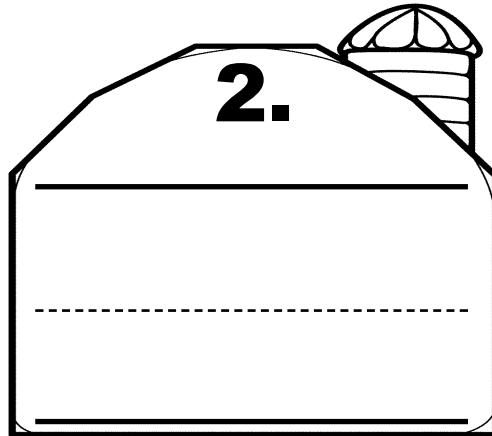

A barn with a silo on the right side. The barn has a large arched opening with a solid top line, a dashed middle line, and a solid bottom line for writing.

**3.**

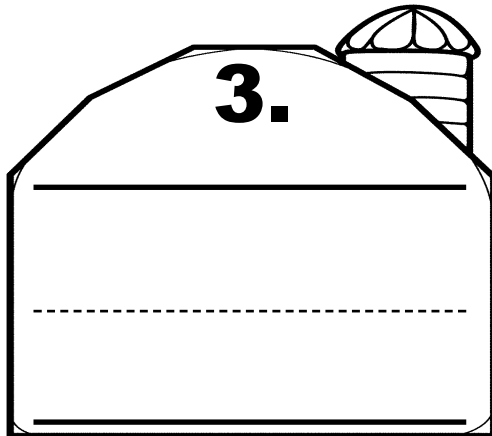

A barn with a silo on the right side. The barn has a large arched opening with a solid top line, a dashed middle line, and a solid bottom line for writing.

**4.**

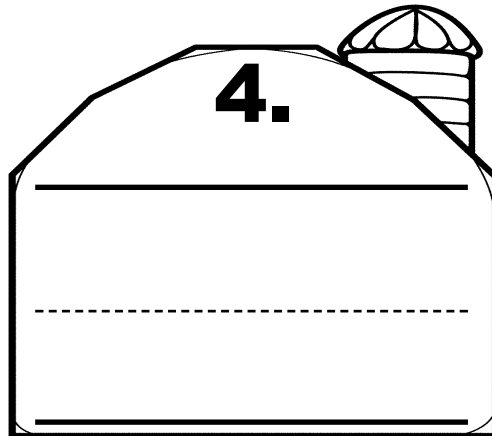

A barn with a silo on the right side. The barn has a large arched opening with a solid top line, a dashed middle line, and a solid bottom line for writing.

**5.**

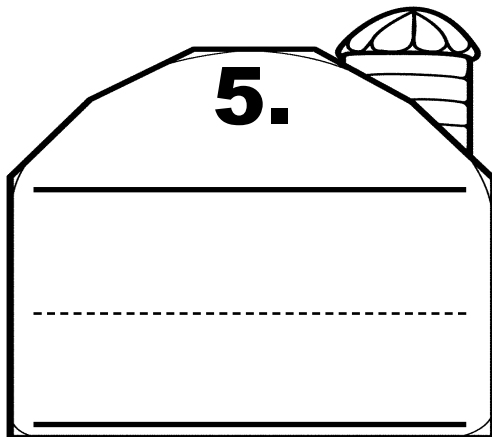

A barn with a silo on the right side. The barn has a large arched opening with a solid top line, a dashed middle line, and a solid bottom line for writing.

**6.**

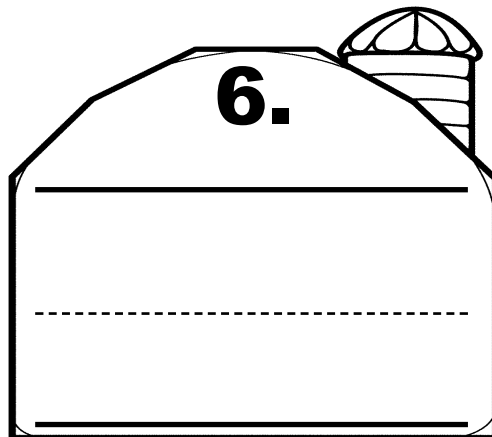

A barn with a silo on the right side. The barn has a large arched opening with a solid top line, a dashed middle line, and a solid bottom line for writing.

# Barnyard Math

Count and write the number.

1.



\_\_\_\_\_ trees

2.

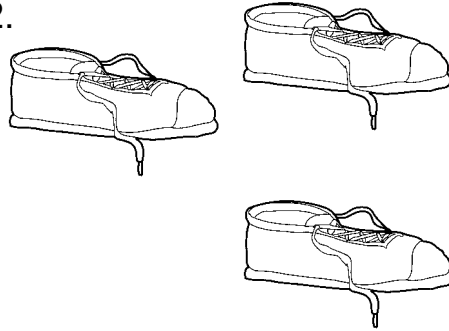

\_\_\_\_\_ shoes

3.

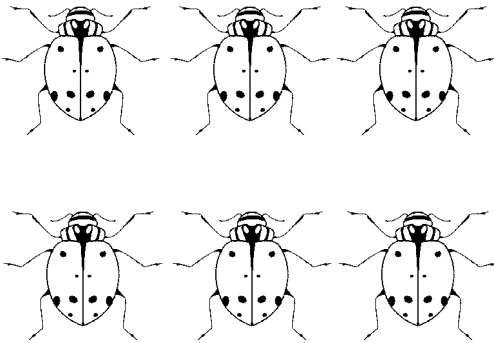

\_\_\_\_\_ bugs

4.

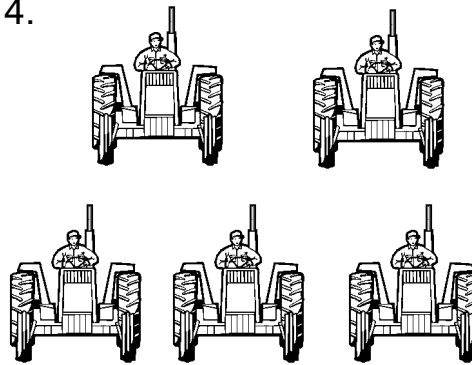

\_\_\_\_\_ tractors

5.

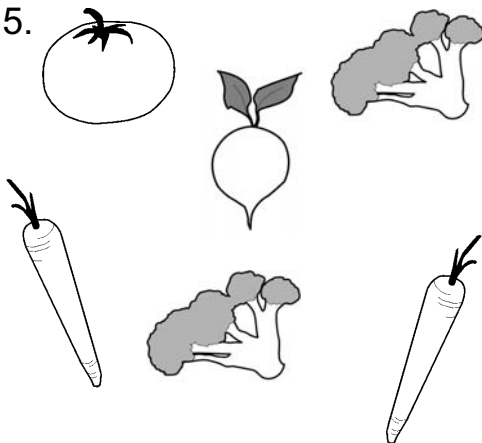

\_\_\_\_\_ vegetables

6.

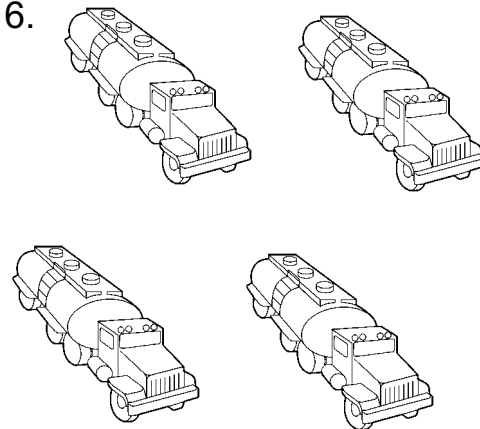

\_\_\_\_\_ trucks



# Ag Homophones

Draw lines from the words in the first column to the homophones in the second column.

bail

bore

grays

hoarse

main

bridal

pale

meet

stake

do

rain

gate

bowl

flower

use

heard

dew

ewes

bale

boar

horse

steak

gait

mane

bridle

herd

pail

meat

graze

rein

boll

flour

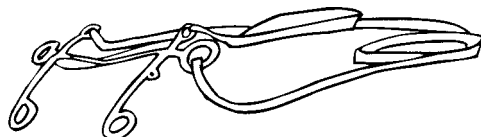
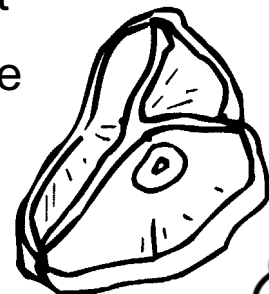

# Lesson Activities and P.A.S.S. Correlation

For the ABC Coloring Book

## Discuss the picture and how the object/picture relates to students' lives

Pre-K:	Social Studies 3.1
Kindergarten:	Speaking 2.1 Social Studies 2.1
Grade 1:	Speaking 2.1, 2.2, 2.5, 2.7 Social Studies 4.1
Grade 2:	Oral/Speaking 2.1,3.2 Social Studies 5.1, 5.2
Grade 3:	Oral/Listening 1.1, 1.2, 2.1, 2.5, 3.2 Social Studies 4.3, 4.4
Grade 4:	Oral/Listening 1.2
Grade 5:	Oral/Listening 3.2 Social Studies 7.5

## Read the paragraph on each page

Pre-K:	Literacy 8.1
Kindergarten:	Reading/Literature 1.1, 1.2, 1.3, 1.4, 1.5, 1.6, 1.7
Grade 1:	Reading/Literature 1.1, 1.2, 4.1, 4.2, 4.3
Grade 2:	Reading/Literature 3.1, 4.1
Grade 3:	Reading/Literature 4.2a
Grade 4:	Reading /Literature 3.1a, 3.1b

## Color the picture

Pre-K:	Small Motor Skills 2.1
Kindergarten:	Small Motor Skills 1.1, 1.2

## Dictate a story about the picture

Pre-K:	Oral Language 1.4
Kindergarten:	Writing 1.2

## Write a story about the picture

Grade 1:	Writing 2.1, 2.5
Grade 2:	Writing 2.2
Grade 3:	Writing 2.2, 2.3
Grade 4:	Writing 2.1
Grade 5:	Writing/Grammar 2.5

## Write an addition subtraction, multiplication, or division numeral and word problem using the items in the picture

Grade 1:	Math 1.2, 3.2, Math Process Standard 1.2, 2.4
Grade 2:	Math 2.4 Math Process Standard 1.2, 2.4
Grade 3:	Math 1.1, 1.2, 2.4,5.1, 5.2 Math Process Standard 1.2, 2.4
Grade 4:	Math Process Standard 2.4
Grade 5:	Math Process Standard 2.4

## Identify the basic shapes in each picture

Pre-K:	Math 3.1
Kindergarten:	Math 3.1
Grade 1:	Math - Geometry 4.1b
Grade 2:	Math - Geometry 4.1b

## Identify the sounds made by animals in the pictures

Pre-K:	Science - Life 3.3
--------	--------------------

## Count the syllables in the Agriculture words

Kindergarten:	Language Arts 2.2
Grade 1:	Reading/Literature 2.2

## Create a list of words that rhyme with the Agriculture words

Grade 1:	Reading/Literature 2.1
----------	------------------------

## Classify categories of words (ie. Which are the fruits/vegetables)

Grade 1:	Reading/Literature 4.4
Grade 1,2,3,4:	Science Process Standard 2.1
Grade 5,6,7,8:	Science Process Standard 2.1

## Create a simple poem about the picture

Grade 1:	Writing 2.4
Grade 2:	Writing 2.5
Grade 3:	Writing 2.5
Grade 4:	Writing 2.2

## Recognize adjectives that describe the pictures

Grade 1:	Writing 3.1e
Grade 2:	Writing /Grammar 3.1g
Grade 3:	Writing 3.1i
Grade 4:	Writing 3.1h
Grade 5:	Writing 3.1f
Grade 6:	Writing 3.1e
Grade 7:	Writing 3.1h
Grade 8:	Writing 3.1f

## Compare and contrast similar and/or different characteristics

Grade 1,2,3,4,5:	Science Process Standard 1.2
------------------	------------------------------

## Use of Homophones

Grade 2:	Reading 3.2
Grade 3:	Reading 2.3

## Use of ABC Order

Grade 1:	Reading 8.1a
----------	--------------

